

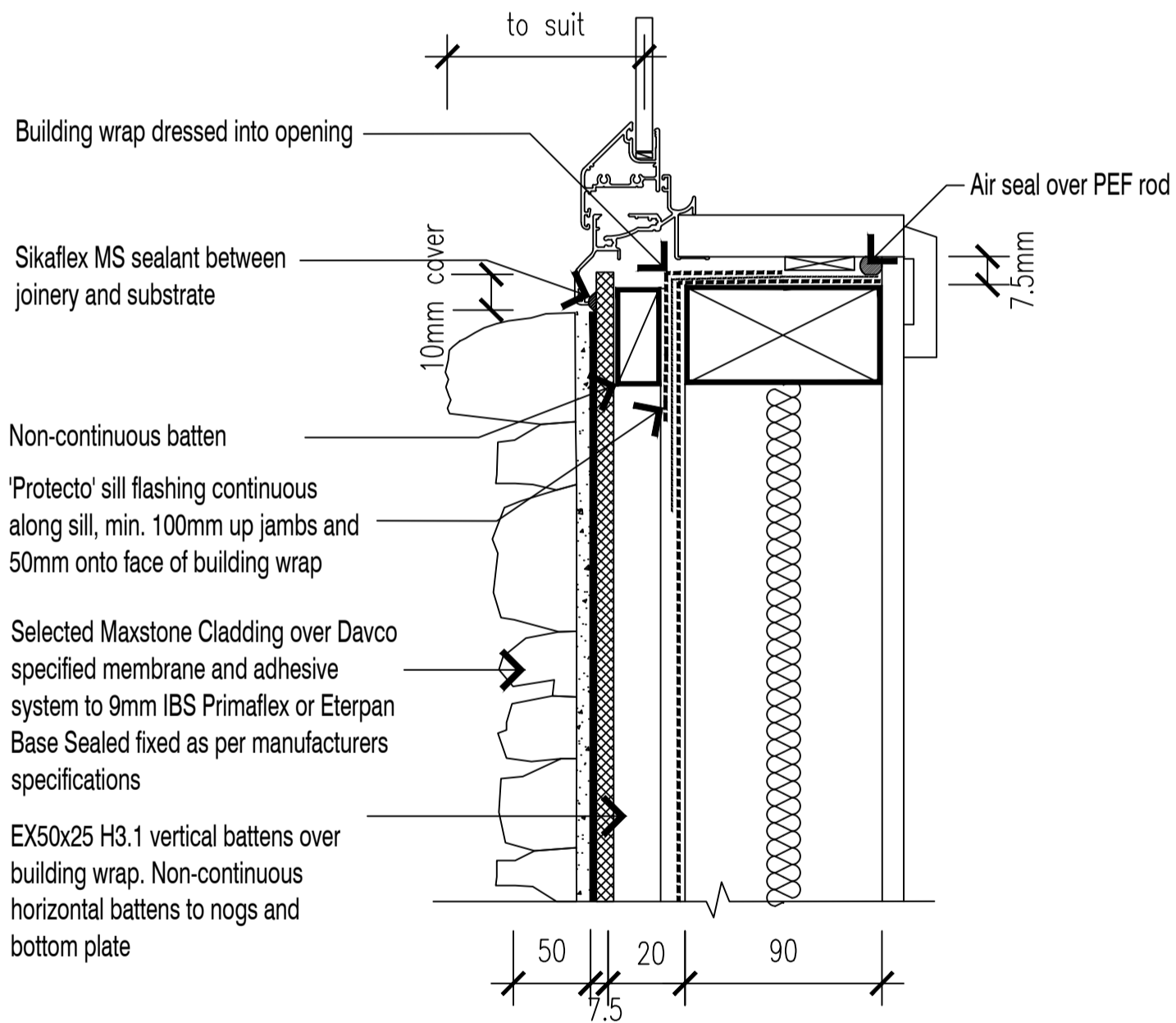

# WINDOW SILL 80MM SILL STANDARD APPLICATION

Scale	Date
NTS	26/08/2019
TILEMAX	MAXSTONE



**NOTE:** EX50X25 BATTENS CAN BE SUBSTITUTED WITH EX50X50 WHERE APPROPRIATE

**NOTE:** SUBSTRATE TO BE FIXED IN STRICT ACCORDANCE WITH MANUFACTURER RECOMMENDATIONS AND LITERATURE